

**Lucent Technologies**  
Bell Labs Innovations



**INTUITY™**

Voice/FAX Messaging User's Guide

585-310-733  
Comcode 107731481  
Issue 2  
February 1996

**Copyright © 1998, Lucent Technologies**  
**All Rights Reserved, Printed in U.S.A.**

#### **Notice**

Every effort was made to ensure that the information in this book was complete and accurate at the time of printing. However, information is subject to change.

#### **Your Responsibility for Your System's Security**

Toll fraud is the unauthorized use of your telecommunications system by an unauthorized party, for example, persons other than your company's employees, agents, subcontractors, or persons working on your company's behalf. Note that there may be a risk of toll fraud associated with your telecommunications system and, if toll fraud occurs, it can result in substantial additional charges for your telecommunications services.

You and your system manager are responsible for the security of your system, such as programming and configuring your equipment to prevent unauthorized use. The system manager is also responsible for reading all installation, instruction, and system administration documents provided with this product in order to fully understand the features that can introduce risk of toll fraud and the steps that can be taken to reduce that risk. Lucent Technologies does not warrant that this product is immune from or will prevent unauthorized use of common-carrier telecommunication services or facilities accessed through or connected to it. Lucent Technologies will not be responsible for any charges that result from such unauthorized use.

#### **Lucent Technologies Fraud Intervention**

If you *suspect that you are being victimized* by toll fraud and you need technical support or assistance, call Technical Service Center Toll Fraud Intervention Hotline at 1 800 643-2353.

#### **Lucent Technologies Web Page**

The world wide web home page for Lucent Technologies is:  
<http://www.lucent.com>

#### **Federal Communications Commission Statement**

**Part 15: Class A Statement.** This equipment has been tested and found to comply with the limits for a Class A digital device, pursuant to Part 15 of the FCC Rules. These limits are designed to provide reasonable protection against harmful interference when the equipment is operated in a commercial environment. This equipment generates, uses, and can radiate radio-frequency energy and, if not installed and used in accordance with the instructions, may cause harmful interference to radio communications. Operation of this equipment in a residential area is likely to cause harmful interference, in which case the user will be required to correct the interference at his own expense.

**Part 68: Answer-Supervision Signaling.** Allowing this equipment to be operated in a manner that does not provide proper answer-supervision signaling is in violation of Part 68 Rules. This equipment returns answer-supervision signals to the public switched network when:

- Answered by the called station
- Answered by the attendant
- Routed to a recorded announcement that can be administered by the CPE user

This equipment returns answer-supervision signals on all DID calls forwarded back to the public switched telephone network. Permissible exceptions are:

- A call is unanswered
- A busy tone is received
- A reorder tone is received

#### **Ordering Information**

**Call:** Lucent Technologies BCS Publications Center  
Voice 1 800 457-1235 International Voice 317 322-6791  
Fax 1 800 457-1764 International Fax 317 322-6699

**Write:** Lucent Technologies BCS Publications Center  
2855 N. Franklin Road  
Indianapolis, IN 46219

**Order:** Document No. 585-310-733  
Comcode 107731481, Issue 2, February 1996

For additional documents, refer to the section in "About This Document" entitled "Related Resources."

You can be placed on a standing order list for this and other documents you may need. For more information on standing orders, or to be put on a list to receive future issues of this document, contact the Lucent Technologies Publications Center.

#### **Acknowledgment**

This document was prepared by the Product Documentation Development, Lucent Technologies, Denver, CO.

---

# Contents

■ Welcome	1
■ Call Answering	1
■ Voice Mail	1
■ FAX Messaging	1
■ Intuity Advantages	2
■ Voice Prompts and Help	2
■ Terms and Concepts	3
Activity Menu	3
Address	3
Address Before Record (ABR)	4
Autodelete	4
Autoprint	4
Header	4
Mailbox	5
Personal Fax Extension	6
■ How to Navigate Your Mailbox Options	7
■ How to Log In	9
Creating or Changing Your Password	10
Recording Your Name	11
Creating Your Personal Greeting	12
Recording Your Basic Greeting	12
Composing a Single Voice-fax Extension Greeting	13

---

# Contents

Composing a Greeting If You Have a Personal Fax Extension	13
■ How to Record and Send Messages	14
Setting Addressing Options	15
Selecting Delivery Options	15
Creating and Sending a Fax-only Message (ABR on)	16
Creating and Sending a Voice Message (ABR on)	17
Creating and Sending a Voice Message (ABR off)	19
Creating and Sending a Voice-fax Message (ABR on)	21
Sharing Fax Machines	23
■ How to Get and Respond to Messages	23
Listening to a Message Header	23
Responding to a Message	24
Printing a Fax	24
Acting on a Header or Message	25
Scanning Messages Quickly	26
■ How to Create and Use Multiple Personal Greetings	26
Call Types	27
Defining Call Types (the first time)	27
Changing Call Type Definition	28
Assigning Greetings to Call Types	29
Activating Previously Recorded Greetings	29
Scanning All Greetings	30

---

# Contents

■ How to Access Outgoing or Filed Messages	32
Accessing Outgoing Messages	32
Selecting a Message	32
Modifying a Message	33
Re-sending a Message	34
■ How to Create Mailing Lists	35
Creating a List	35
Deleting Addresses from a List	36
Scanning List Summaries	37
Reviewing and Modifying a List	38
■ How to Create a Personal Directory	39
Creating and Appending a Directory	39
Reviewing and Deleting Entries from a Directory	40
■ How to Use Directory Assistance	41
■ How to Leave a Call Answer Message	42
■ Command Summary	44
■ Tips and Highlights	45
General Message Handling	45
Leaving Messages When No One Answers	47
Sending Voice Mail	47

---

# Contents

---

## **Welcome**

---

INTUITY™ Voice/FAX Messaging is a powerful call answer, voice mail, and fax-message system. Besides sending and receiving voice mail, you can send, receive, forward, and voice annotate faxes.

## **Call Answering**

---

INTUITY Voice/FAX Messaging answers calls when you are unavailable or too busy to answer your telephone. Callers may then leave messages in your voice “mailbox.” Later, you can access your mailbox to get those messages.

## **Voice Mail**

---

INTUITY Voice/FAX Messaging lets you record voice and voice-fax messages in advance and send them directly to the mailboxes of other system users without actually calling their telephones.

Conversely, other users can record and send voice mail messages and voice-fax messages directly to your mailbox. When convenient, you can access your mailbox to get those messages.

## **FAX Messaging**

---

INTUITY Voice/FAX Messaging lets you send, receive, and voice annotate faxes. You can forward, voice annotate, and re-send received faxes; or direct faxes to printers, PCs, or LAN fax servers.

You can send or forward a fax to any address within your system (and append a voice message to the fax if you choose); or you may elect to send or forward only a fax to an address outside your system. You can send or forward faxes to internal extensions, by using system mailing lists, and/or to external numbers, by addressing your fax messages individually.

---

## Intuity Advantages

---

INTUITY Voice/FAX Messaging provides four key voice and fax advantages:

Mobility	<p>You can access your voice, fax, and voice-fax messages from anywhere.</p> <p>You can retrieve a fax from your mailbox and have it printed anywhere a fax machine is available.</p> <p>With compatible fax software and a modem, you can access and download faxes to a PC or laptop computer for later use.</p>
Convenience	<p>You can retrieve your voice, fax, and voice-fax messages from your desktop, from your home office, from anywhere in the country, or from across the world.</p> <p>You can also retrieve your voice, fax, and voice-fax messages any <i>time</i> you want.</p>
Privacy	<p>You control when and where a voice or fax message is retrieved, and where a fax is printed, so you can be sure that it ends up in your hands only.</p>
Security	<p>Only you can retrieve your voice, fax, and voice-fax messages using your password-protected login to access your mailbox.</p>

## Voice Prompts and Help

---

INTUITY Voice/FAX Messaging voice prompts tell you what to do at every step in a task. Once you have selected the appropriate Activity Menu option, you can *rely solely on the voice prompts* to figure out what to do.

To find help at any time, press **[\*] [H]**. The voice prompts define what step you're on and what your options are.

To return to the Activity Menu, press **[\*] [R] ([\*] [7])**.



---

## Terms and Concepts

---

### Activity Menu

---

After you log into the system, you have six principal keypad activities, represented by the Activity Menu graphic below. As you press keys in the Activity Menu to access the principal functions, you move to different menu levels and the keys change meaning.

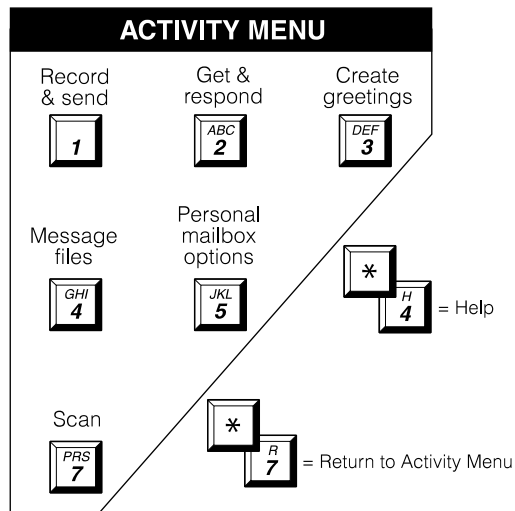

### Address

---

A telephone number (usually an extension) or a name specified for an outgoing voice, fax, or voice-fax message (equivalent to an address on a letter).

---

## **Address Before Record (ABR)**

---

A user-selected option (on/off) that defines whether a message is addressed before it is created, or created before it is addressed.

## **Autodelete**

---

A user-selected option (on/off) that defines whether the system automatically removes faxes from the mailbox as they are printed.

## **Autoprint**

---

A user-selected option (on/off) that defines whether the system automatically sends faxes to a designated fax printer.

## **Header**

---

A summary of an incoming voice, fax, or voice-fax message (equivalent to a return address and postmark on a letter). It includes the length of the message in minutes and/or seconds, and a page count for fax messages. The three header types are:

### **Voice message**

“Message from Norman Bates, received 7:34 AM, Friday, April seventh, 70 seconds, extension 77956.”

### **Fax message**

“Fax call from extension 40668, received 1:22 PM, Thursday, August third, 4 pages.”

### **Voice-fax message**

“Voice and fax message from Eileen Dover, received 3:16 PM, Monday, December twelfth, 45 seconds, 3 pages, extension 75433.”

---

## Mailbox

---

Your personal storage area for incoming and outgoing voice, fax, or voice-fax messages and headers.

Your incoming and outgoing voice, fax, or voice-fax messages are stored in categories according to their status. The system keeps incoming messages until you delete them or until an automatic deletion date. Because space is limited, it is wise to review and delete messages regularly.

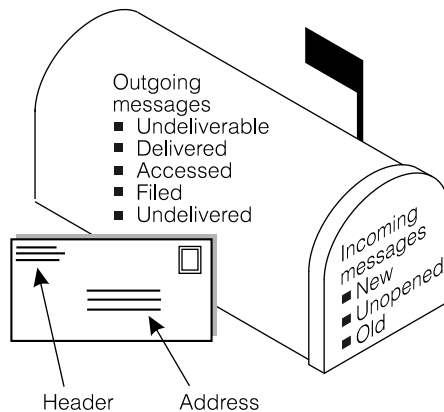

### Incoming Messages (received by you)

Voice Message	A voice-only transmission.
Fax Message	A fax-only transmission.
Voice-Fax Message	A fax transmission annotated with a voice message.

---

New	Fax, voice, or voice-fax messages you haven't retrieved.
Unopened	Fax, voice, or voice-fax message headers to which you've listened, but have not yet listened to the message itself.
Old	Fax, voice, or voice-fax messages to which you've listened or printed, but haven't deleted.

### **Outgoing Messages (sent by you)**

Accessed	Fax, voice, or voice-fax messages delivered and listened to by the recipient.
Undelivered	Fax, voice, or voice-fax messages not yet sent but scheduled for future delivery. You can listen to, re-address, and re-record these messages any time before delivery.
Undeliverable	Fax, voice, or voice-fax messages that could not be delivered, normally because the intended recipient's mailbox is full. You can listen to, re-address, and re-record these messages.
Filed	Copies of outgoing fax, voice, or voice-fax messages that you've saved to re-send and/or modify.

### **Personal Fax Extension**

---

If you receive frequent faxes, or use your telephone extensively, your system administrator may set up a second fax-only extension, your *personal fax extension*.

A personal fax extension has these characteristics:

- It stores faxes only.
- It doesn't accept voice messages.

- 
- The system sends faxes and the fax portion of voice-fax messages to this extension automatically. Fax headers are stored in your primary mailbox.
  - Fax-only messages addressed to your fax extension *do not* ring your telephone.
  - Fax-only messages addressed to your fax extension *do* trigger your message light.
  - Activity Menu access to your personal fax extension and your personal mailbox extension is the same—the system *does not* separate them.
  - You *cannot* create a greeting for your personal fax extension; it is set by the system. Example: “Fax extension for (your name). Press START on your fax machine now.”



**NOTE:**

If you do not have a personal fax extension, you have a single number for both voice and fax messages. Because of the system memory demands of fax messaging, you are urged to act on fax, voice, or voice-fax messages immediately to clear them from your mailbox. Your system administrator establishes your mailbox memory size.

## How to Navigate Your Mailbox Options

---

Of the principal Activity Menu activities, Personal Mailbox Options [5] affects the entire system more than any other. Mailbox Options contain the Subscriber (user) Administration submenu, from which you select and define the conditions that control mailing lists, personal directories, fax printing, password, account names, and call answer options. Each submenu choice is explained in greater detail in subsequent sections of this booklet.

---

To select and set your personal mailbox options, you will press **5** from the Activity Menu, and select from these submenus:

1. Mailing list submenu

- 1** To create a list
- 2** To scan an existing list
- 3** To modify a list

2. Personal directory submenu

- 1** To create a directory
- 2** To review a directory

3. Fax option submenu

- 1** Select a default print number  
Y or N Turn autoprint on or off
- 9** Select autodelete  
Y or N Turn autodelete on or off

4. Password

5. Account name

6. Addressing options submenu

- 1** Address before record (ABR) on or off

7. Call answer options

- 1** Call answer on/off

One personal mailbox option is not explained later, **7 1** call-answer on/off. If you are away from your telephone for extended periods (illness, vacation, sabbatical, etc.), you may wish to turn your call answer capability off so your mailbox doesn't fill up. To administer your call answer options, see **7** above.



## NOTE:

Because the system doesn't signal a caller that call answer is off, compose a greeting that tells callers when call answer is disabled and, if you wish, other options for reaching you.

## How to Log In

Your system administrator establishes your extension or telephone number and a default password for login and assigns a system mailbox-access number, your *system extension*. You should receive directions specific to your system *prior* to logging in.

After you dial the system extension and enter your extension and the default password, you are at the Activity Menu. The system voice prompts tell you what to do and what your options are. At any time, press **\* H \* 4)** to get information about your current options.

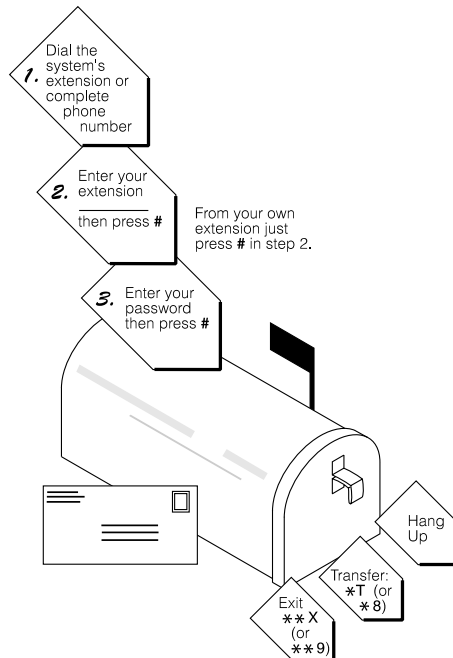

---

## **Creating or Changing Your Password**

After logging in to your mailbox the first time, replace the default password with your personal password.

To change your password any time after logging in:

1. Press **[5]** **[4]** from the Activity Menu.
2. Enter new password (up to 15 digits) and press **[#]** .
3. Re-enter new password and press **[#]** .



### **CAUTION:**

*To ensure the security of your messages and the system, do not use a password that uses:*

- Ascending or descending digits (for example, 1234 or 4321)
- The same digits (for example 0000)
- Digits corresponding to your name or initials (for example, 5646 for John)
- The current year (for example, 1993)
- The same number as your extension (for example, extension 3455, password 3455)
- A reverse extension (for example, extension 3455, password 5543)
- Numbers that identify you, such as your social security number, employee ID, room number, or department
- A programmable function key or speed-dial key.



### **NOTE:**

Change the default password to your personal password immediately after you log in to the system the first time.



---

## Recording Your Name

---

Record your name to replace the system greeting for your mailbox. Callers hear your voice speaking your name and feel comfortable about leaving messages.

You can record your name any time after logging in.

1. Press **5 5** from the Activity Menu.
2. Say your name after the tone.
3. Press **1**
4. **(Optional)**

Press one of the following:

- 1** to re-record (return to step 2).
  - 2 3** to play back.
5. Press **#** to approve.



### NOTE:

This capability may not be available on your system.

---

### Tips

Usually, you don't have to wait for the voice prompts; you can dial through them to enter a command, without waiting, from anywhere in the system.

You can't dial through error messages and important announcements the system wants you to hear. When you try to dial through prompts at these times, you hear a beep.

After leaving a call answer message for someone else, access your own voice mailbox by pressing **\* R (\* 7)**.

---

---

## Creating Your Personal Greeting

---

Your system allows you to record and store several personal greetings, each for a specific situation. You can manually activate each greeting as needed (basic mode), or you can keep a number of greetings active at once. See “How to Create Multiple Personal Greetings.”

## Recording Your Basic Greeting

---

1. Press **3** from the Activity Menu.
2. Listen to a summary of active greetings.
3. Press **1** to record or re-record a greeting.
4. Enter a number (1 to 9) for the greeting.
5. Speak greeting at the tone.
6. **(Optional)**  
To edit your greeting:  
Press **1** to stop recording or pause.  
Press one of the following:  

<b>1</b>	Continue recording.
<b>2 3</b>	Play back.
<b>* D (* 3)</b>	Delete (and begin again).
7. Press **#** to approve.
8. Do one of the following:
  - Press **#** to leave the greeting inactive.
  - Follow the prompts to activate the greeting.

---

## Composing a Single Voice-fax Extension Greeting

---

Fax messaging is a new capability and many callers will be unfamiliar with it at first. Callers will find it helpful if you record a greeting that briefly instructs them about your fax messaging.

Explain *how to transmit* a fax:

“This is Richard Hyatt at Gobels & Nixon. I’m away from my desk; please leave a message at the tone. If you want to include a fax with your message, press START on your fax machine when you finish speaking. If you want to send *only* a fax, press START on your fax machine *now*.”

## Composing a Greeting If You Have a Personal Fax Extension

---

While it is a true mailbox, a personal fax extension also acts as a storage site to reduce the memory limits of a single voice-fax extension for users who receive many faxes.

Callers *cannot address* voice messages to your personal fax extension.

- A personal fax extension stores faxes only. If you have a personal fax extension, the system automatically sends faxes to this extension.
- Fax messages addressed to your fax extension do not ring your telephone.
- Fax messages addressed to your fax extension do trigger your message light.
- Like voice-mail headers and voice messages, fax headers addressed to your personal fax extension are stored in your primary mailbox.
- In the case of a voice-fax message, a caller must address the message (both fax and voice) to your primary mailbox.

---

If you have a personal fax extension, you may want to list your extension on your business card or company stationery and/or instruct callers to send faxes to your fax-only number.

Instructional greeting if you have a personal fax extension:

“This is Diane Downer at the Commander Heater Company. I’m unable to take your call; please leave a message at the tone. If you want to send me a fax, please call my fax number at 332-3626.”

## **How to Record and Send Messages**

---

Sending faxes and creating and sending voice and voice-fax messages are similar in all respects but one — to send a fax, you must access the system *from the fax machine* from which you wish to transmit.

You can record a voice message and attach it to a fax in two ways:

- From the system fax machine from which you wish to transmit.
- From any telephone from which you can access your mailbox. See “Sharing Fax Machines.”



### **NOTE:**

Advanced fax users will quickly note that a fax *can be* transmitted in the *manual send* mode from a modem-enabled PC running compatible facsimile software. To do so, a user should follow the conventions set forth in the fax software user instructions. It is strongly recommended that users address software concerns with system administration *before* attempting to transmit a fax from a PC.

---

## Setting Addressing Options

---

Before moving into the “Creating a Message” category, it is necessary to determine whether messages will be recorded first or addressed first.

The options are address before record (ABR) *on* or address before record *off*. Once set, addressing can be left in the selected option with no further action by the user, or modified according to individual requirements.

### NOTE:

In fax-messaging mode, the system uses your active phone line to send the fax, then hangs up when transmission is complete. Thus, you must *address a fax before* you send it. It is recommended that you elect ABR *on*.

To change the ABR setting:

1. Press **5** (Personal Mailbox Options) from the Activity Menu.
2. Press **6**. You hear the prompt, “Address before record turned on” (or “off”).
3. Press **1** to change ABR setting.

## Selecting Delivery Options

---

When you have created/addressed your message, and have moved to sending faxes or creating and sending voice or voice-fax messages, several delivery options are available.

Press **0** to listen to the list of options:

- 1** Make your message private. (Press **1** again to undo.)
- 2** Make your message priority (if available). (Press **2** again to undo.)
- 3** Schedule delivery. (Press **3** again to undo.)

---

To schedule delivery:

1. Enter delivery time (405 = 4:05).
2. Enter [A] (or [2]) for AM or [P] (or [7]) for PM and press [#].
3. Enter delivery month and day (502 = May 2) and press [#].
4. Press [#] to approve or [\*] 3 (or [\*] D) to start over.

[4] File a copy. (Press again to undo.)

[5] To include a fax (in voice-fax mode).

## **Creating and Sending a Fax-only Message (ABR on)**

---

From the system fax machine from which you wish to transmit, access the Activity Menu by entering your system extension and password as you would if you were logging in from your own telephone.

1. Press [1] from the Activity Menu.
2. To address a *fax-only* message, select one of the following:
  - Enter recipient's address (that is, the telephone *extension*, if internal; or the telephone number, if *external*) and press [#].
  - To send to a mailing list:
    - a. Press [\*] [L] to access a list.
    - b. Enter list owner's extension and press [#]. (If you're the owner, just press [#].)
    - c. Enter list ID (name) and press [#].
3. Press [0] to access delivery options.
4. Press [#] to approve address.
5. Press [#] to input fax and send.
6. Insert fax and press START on the fax machine.

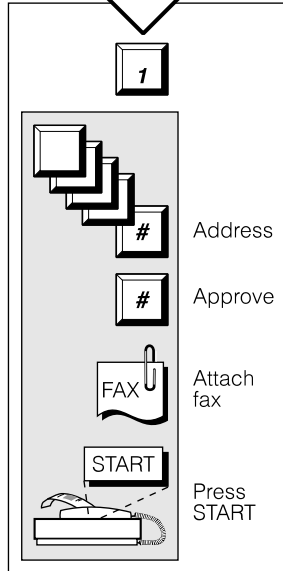
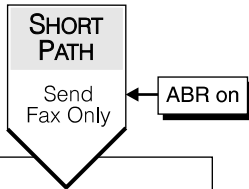

---

## Creating and Sending a Voice Message (ABR on)

---

Access the Activity Menu by entering your system extension and password.

1. Press **1** from the Activity Menu.
2. To address a voice message, select one of the following:
  - Enter recipient's address (that is, the telephone extension, if internal; or the telephone number, if external) and press **#**.
  - To send to a mailing list:
    - a. Press **\* L** to access a list.
    - b. Enter list owner's extension and press **#**. (If you're the owner, just press **#**.)
    - c. Enter list ID (name) and press **#**.
3. Press **0** to access delivery options.
4. Press **#** to approve address.
5. Record message at the tone.
6. **(Optional):**

To edit your message before approving:

  - Press **1** to stop recording or pause.
  - Press one of the following:

<b>1</b>	Continue recording.
<b>2 3</b>	Play back.
<b>* D</b> (or <b>* 3</b> )	Delete (and begin again).
7. Press **#** to approve voice message.
8. Press **#** to send.



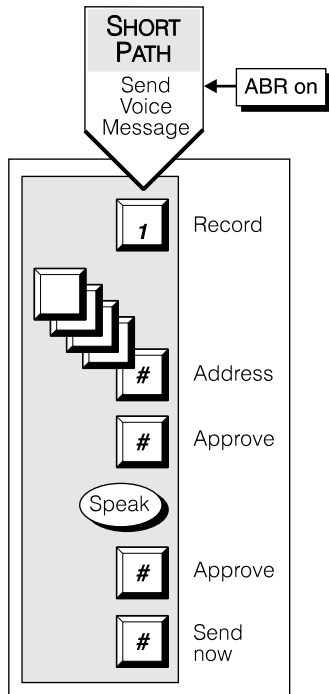

---

## Creating and Sending a Voice Message (ABR off)

---

Access the Activity Menu by entering your system extension and password.

1. Press **1** from the Activity Menu.

2. Record message at the tone.

3. **(Optional):**

To edit your message before approving:

■ Press **1** to stop recording or pause.

■ Press one of the following:

**1** Continue recording.

**2 3** Play back.

**\* D** (or **\* 3**) Delete (and begin again).

4. Press **#** to approve voice message.

5. Address voice message (ABR off).

6. Press **0** to access delivery options.

7. Press **#** to approve address.

8. Press **#** to send.

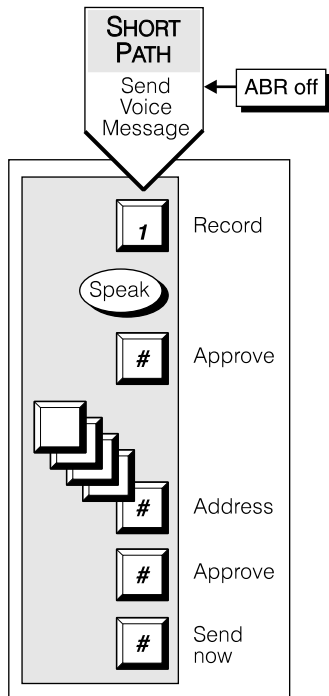

---

## Creating and Sending a Voice-fax Message (ABR on)

---

Access the Activity Menu by entering your system extension and password.

1. Press **1** from the Activity Menu.
2. To address a voice-fax message, select one of the following:
  - Enter recipient's address (that is, the telephone extension, if internal; or the telephone number, if external) and press **#**.
  - To send to a mailing list:
    - a. Press **\* L** to access a list.
    - b. Enter list owner's extension and press **#**. (If you're the owner, just press **#**.)
    - c. Enter list ID (name) and press **#**.

3. Press **#** to approve address.

4. Record message at the tone.

5. **(Optional):**

To edit your message before approving:

- Press **1** to stop recording or pause.
- Press one of the following:

<b>1</b>	Continue recording.
<b>2 3</b>	Play back.
<b>* D</b> (or <b>* 3</b> )	Delete (and begin again)

6. Press **#** to approve voice message.

7. Press **0** to access delivery options.

- a. Press **5** to attach a fax
- b. Press **#** to input fax and send.

8. Insert fax and press START on the fax machine.

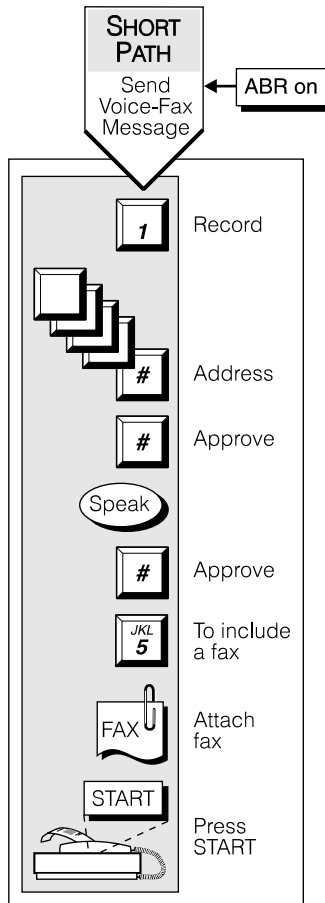

**➤ NOTE:**

The button label on your fax machine may be different from **START**. Common alternate keys for this function are **SEND**, **TRANSMIT**, and **CONNECT**. At the prompt, press the key that begins the transmission process.

---

## **Sharing Fax Machines**

---

If you use a shared or public fax machine (such as a departmental fax), you may wish to avoid tying it up while you transmit to multiple addresses.

You may want to store a fax for later use, or it may simply be more efficient to send a fax from your own desk, particularly if you want to attach a private voice message to your fax.

In any case, you can send a fax and/or fax message to your own mailbox (or a fax-only message to your personal fax extension) by keying your extension as the delivery address. Later, you can access the fax and change the delivery options and/or voice-fax message from the Activity Menu.

## **How to Get and Respond to Messages**

---

### **Listening to a Message Header**

---

1. Press **[2]** from the Activity Menu.
2. Press any of the following:
  - [0]** Listen
  - [2]** Rewind (or return to previous)
  - [3]** Play back the header

---

## **Responding to a Message (Optional)**

You can respond to a message during or after listening to the header or message.

1. Press  to call sender or press one of the following:
  - Reply to sender by voice mail.
  - Forward with comment at beginning.
  - Forward with comment at end.
2. With ABR on, address your message, then record new message.
3. With ABR off, record your message, then address.
4. Press  to approve.
5. Schedule delivery or press  to send now.

## **Printing a Fax**

You access and print faxes from the Activity Menu. If the autoprint option is active, your fax prints automatically to a designated printer. The message and header stay in your mailbox until you delete them. You can reprint if you wish.

To select a default printer or specify a printer destination:

1. After listening to the header or message, press  , then do one of the following:
  - Direct fax to a default print number.
  - Turn autoprint on/off
  - Turn autodelete on/off. If autodelete is active, faxes are deleted after they are printed.
2. If autoprint is not active, access your mailbox to retrieve the fax, and listen to the message header.

---

3. Press **\*** **1** to print the fax, and choose one of these print options:

- |                                     |   |
|-------------------------------------|---|
| <b>#</b>                            | Print to <i>&lt;default fax machine extension or name&gt;</i> .   |
| <i>&lt;printer ext&gt;</i> <b>#</b> | Specify a destination. This number becomes the default for the remainder of the call.   |
| <b>*</b> <b>6</b>                   | Print at this fax machine (if you have fax capability at your desk or are at the default fax machine or any other fax machine, including off-site). |

Wait for the START prompt.



**NOTE:**

The button label on your fax machine may be different from START. Common alternate keys for this function are PRINT, RECEIVE, and REC/PORT. At the prompt, press whatever key begins the printing process.

## Acting on a Header or Message

After you have listened to a header or message, you can choose from several options.

1. Press any of the following:

- |   |   |
|---|---|
| <b>*</b> <b>D</b> ( <b>*</b> <b>3</b> )                   | Delete message  |
| <b>*</b> <b>*</b> <b>U</b> ( <b>*</b> <b>*</b> <b>8</b> ) | Restore the last message you deleted                      |
| <b>#</b>  | Save and skip to next message                             |
| <b>*</b> <b>*</b> <b>H</b> ( <b>*</b> <b>*</b> <b>4</b> ) | Hold message in current category and skip to next message |
| <b>*</b> <b>#</b>   | Skip to next message category                             |



**NOTE:**

If you have a personal fax extension, you receive only voice messages and fax message headers through your telephone set. Faxes go directly into your personal fax extension without ringing your telephone.

Fax headers do trigger your message light. The header may give you a length of time in seconds. This is the length of the message. The header also gives you the fax page count.

---

## Scanning Messages Quickly

---

Once you are familiar with how to get messages, try the easier autoscans method. Autoscans is most useful for mobile telephone users, because it requires touching only two buttons.

1. Press **7** from the Activity Menu.
2. Press one of the following:
  - 1** Scan headers and messages.
  - 2** Scan headers only.
  - 3** Scan messages only.
  - 4** Print all new faxes.
3. Use the Respond and Act On options as necessary. The system pauses three seconds between messages.

---

## How to Create and Use Multiple Personal Greetings

---

After you have recorded several personal greetings, you may want to assign those greetings to specific types of incoming calls. Besides the basic mode of using one greeting for all calls, you can set up specific greetings for:

- 1) internal and 2) external calls
- 1) busy and 2) no answer calls

- 
- 1) prime-time internal, 2) prime-time external, and 3) out-of-hours calls
  - 1) prime-time busy, 2) prime-time no answer, and 3) out-of-hours calls

The first step is to define the types of calls you want to differentiate; then move on to changing call type definitions and assigning greetings to call types.

## **Call Types**

---

Internal	Those from callers at your business location.
External	Those from outside your business location.
Busy	Those that come in when you are using your telephone line(s).
No answer	Those that come in when you do not answer.
Out-of-hours	Those that come in after standard business hours—defined by your system administrator.  (Weekend greetings must be activated manually—basic mode only.)

## **Defining Call Types (the first time)**

---

1. Press **3** **4** from the Activity Menu.
2. Press one of the following:
  - 1** Differentiate internal/external calls.
  - 2** Differentiate busy/no answer calls.
3. Press one of the following:
  - 3** Differentiate out-of-hours calls.
  - 4** Make no distinction between prime time and out-of-hours calls.

---

## Tips

When you select the out-of-hours call type, the other call types automatically apply only to prime-time calls.

You must make a choice between internal/external and busy/no answer call types. The system is not set up to handle both sets of situations simultaneously.

---

## **Changing Call Type Definition**

---

1. Press **3** **4** from the Activity Menu.
2. Press any of the following:
  - 1 Differentiate internal/external calls.
  - 2 Differentiate busy/no answer calls.
  - 3 Differentiate out-of-hours calls.
  - 4 Turn off out-of-hours differentiation.
  - 5 Use a single greeting for all calls (negate call type definition).
3. Press **#** to approve, then proceed to “Assigning Greetings to Call Types.”

After you have recorded multiple personal greetings and defined the call types to which you want to assign those greetings, use the following procedures to assign greetings to call types.

---

## Assigning Greetings to Call Types

---

1. Press **[3]** from the Activity Menu.
2. Listen to the summary of active greetings.
3. Press **[3]** to activate a greeting.
4. Enter a number (0 to 9) to indicate which greeting you want to assign to a call type.
5. Press any of the following:
  - 1 Use the greeting for each call type.
  - 2 Use the greeting for internal (or busy) calls.
  - 3 Use the greeting for external (or no answer) calls.
  - 4 Use the greeting for out-of-hours calls.
  - 5 Use a single greeting for all calls (negate call type definition).
6. Press **[#]** to approve.
7. Press **[\*] [R] (\* [7])** to return to the Activity Menu.



### NOTE:

To set up different greetings strictly for prime-time and out-of hours calls, you must assign the same greeting to the two prime-time calls types (internal and external or busy and no answer). Listen to the voice prompts for guidance.

## Activating Previously Recorded Greetings

---

1. Press **[3] [3]** from the Activity Menu.
2. Enter the greeting number.
3. Follow the prompts to activate for all calls or for individual call types.

---

## Scanning All Greetings

---

1. Press **3** **2** from the Activity Menu.
2. Listen to first greeting status statement.
3. Press any combination of the following:
  - 0** Listen to a greeting.
  - 1** Re-record a greeting.
  - \*** **D** (**\*** **3**) Delete and skip to the next greeting.
  - 2** Return to the previous greeting.
  - #** Save and skip to the next greeting.
4. Press **\*** **#** to quit scanning.

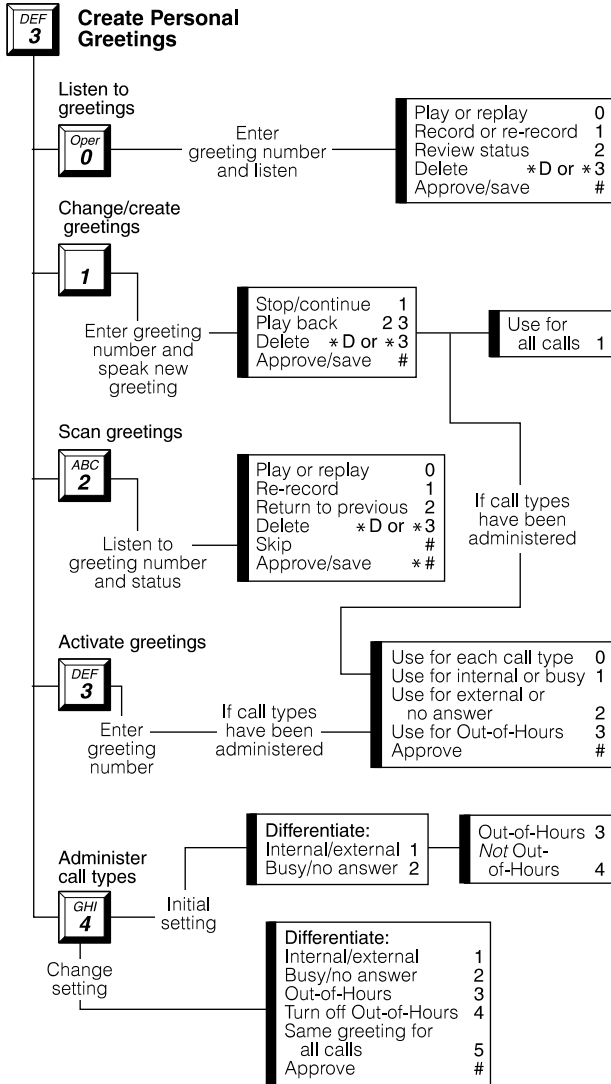

---

## How to Access Outgoing or Filed Messages

---

To check the status of outgoing messages, access them by following the steps listed below, then move on to selecting, modifying, and re-sending them.

### Accessing Outgoing Messages

---

1. Press **[4]** from the Activity Menu.
2. Listen to the first category and message header. Categories:

Undeliverable	Can't be delivered, usually because the recipient's mailbox is full. You can listen to, re-address, and re-record these messages.
Filed	Copies of outgoing messages you've saved to re-send and/or modify.
Undelivered	Not yet sent because they're scheduled for future delivery. You can listen to, re-address, and re-record these messages prior to delivery.
Delivered	Delivered but not yet listened to.
Accessed	Delivered and listened to.

### Selecting a Message

---

When you have accessed your filed messages, select individual messages to modify by following the selection procedure.

1. Press any or none of the following:
  - [0]** Listen to the message.
  - [2] [3]** Play back the message header.
  - [\*] [D] ([\*] [3])** Delete and skip to the next message.

---

2 2

Return to previous messages.

#

Save and skip to the next message.

#

Skip to the next message category



**NOTE:**

For delivered or accessed messages, you can listen to the headers only. You can't change or re-send these messages. After you review an accessed message header, the system deletes the header automatically.

## **Modifying a Message**

---

When you have selected a message to modify or re-send, choose one of the following options.

1. Press **1** to modify and/or re-send the selected message.
  - Press **#** to re-send the message as is.
  - To re-record the message:
    - a. Press **1**.
    - b. Speak message at the tone.
    - c. Edit normally.
    - d. Press **#** to approve.



**Tips**

You can modify/re-send three types of outgoing messages:

- Undelivered (scheduled for future delivery)
- Undeliverable (incorrect address or recipient's mailbox is full)
- Filed



---

Press **#** **#** to re-send an undelivered message to the original recipient only.

---

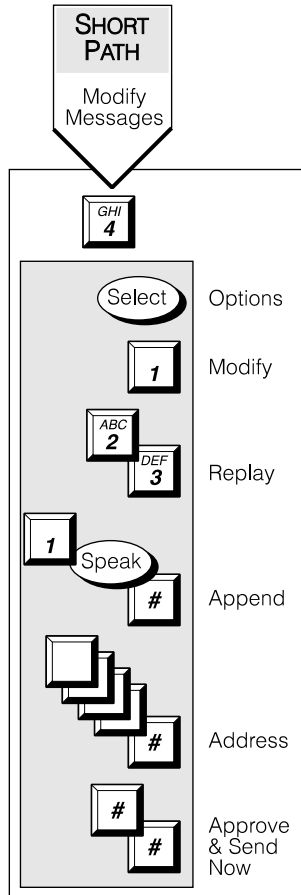

---

## Re-sending a Message

---

When you have selected a message to modify/re-send, choose one of the following options to re-direct your message.

1. For filed and undeliverable messages:
  - a. Enter address(es) or list via **\* L (\* 5)**.
  - b. Press **# #** to approve and send immediately.  
or
  - c. Enter delivery options and press **#**.
2. For undelivered messages:
  - a. Enter additional addresses and press **#**.
  - b. Press **\* 1** to review and edit original addresses.
  - c. Change delivery times or options.

---

### Tips

If you re-send a filed message, it leaves the file cabinet portion of your mailbox. You must file a copy again to retain it .

The Outgoing Message file consumes much of your system's resources. Be sure to delete messages and headers regularly.

Press **# #** to re-send an undelivered message to the original recipient only.

---

## How to Create Mailing Lists

---

### Creating a List

---

1. Press **5 1 1** from the Activity Menu.
2. Enter list ID (up to 6 letters or digits) and press **#**.

- 
3. Press one of the following:
    - 1 Make the list private.
    - 2 Make the list public
  4. Enter an address and press **#** .
  5. Repeat step 4 until list is complete.
  6. Press **#** to approve.

**NOTE:**

After you address a message using a list, the system asks for more extensions. Do not add extensions that are already used in addressing of the list just appended.

Specify an address as a number or name—press **\* A (\* 2)** to switch modes.

**Tip**

When creating a list, you can also include an existing list by entering **\* L (\* 5)** at step 4.

---

## Deleting Addresses from a List

Delete addresses from a mailing list in two ways:

- Review the list until you find each address, then press **\* D (\* 3)**; or
- At step 4 (when creating a list), press **1** immediately, enter the address to be deleted, and press **\* D (\* 3)**.

Repeat for other addresses.

---

## Scanning List Summaries

1. Press **5** **1** **2** from the Activity Menu.
2. Listen to the list summary.
3. Press any of the following:

- #** Skip to next list.
- \* D (\* 3)** Delete the entire list.
- 0** Review/modify list members. (Return to “Reviewing and Modifying a List.”)

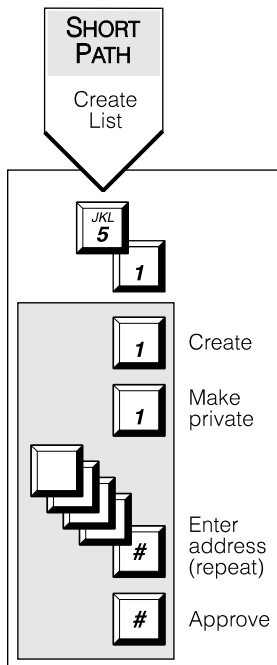

---

## Reviewing and Modifying a List

---

1. Press **[5]** **[1]** **[3]** from the Activity Menu.
2. Enter list owner's extension and press **[#]**. (If you own the list, simply press **[#]**.)
3. Enter list ID and press **[#]**.
4. Listen to the first name, then press any of the following:
  - [#]** Skip to the next name.
  - [\*]** **[D]** (**[\*]** **[3]**) Delete name.
  - [2]** Repeat name.
  - [2]** **[2]** Return to previous name.
  - [\*]** **[1]** Review from beginning.
  - [1]** Add/delete specified entries or change public/private status, then do the following:
    - a. Press Y (**[9]**) or N (**[6]**) to change status.
    - b. Enter address and press **[#]**.
    - c. Listen to name, and if deleting, press **[\*]** **[D]** (**[\*]** **[3]**).
    - d. Repeat b and c for each addition/deletion.
5. Press **[\*]** **[#]** to stop adding/deleting specified entries.
6. Press **[#]** when finished reviewing.

---

## How to Create a Personal Directory

---

The system allows you to create a personal directory of abbreviated names (aliases) for frequently used addresses. It's essentially a sophisticated speed-dialing feature.

### Creating and Appending a Directory

---

You must be addressing by name (**[\*] A/[\*] 2**) to *use* your personal directory. You can *create* your personal directory in name or number addressing mode.

1. Press **[5] [2] [1]** from the Activity Menu.

2. Enter an address and press **[#]**.

3. Listen to your entry's address.

If the name is incorrect, press **[\*] [D] (\* 3)** to delete and repeat steps 2 and 3.

4. Enter your abbreviated version of the address (up to 10 characters) and press **[#]**.

5. Repeat steps 2, 3, and 4 to add more names to your personal directory.

6. Press **[#]** to approve.

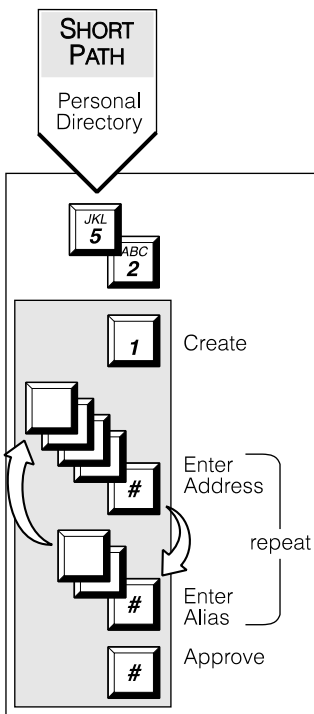

## Reviewing and Deleting Entries from a Directory

---

1. Press **5** **2**.
2. Do one of the following:

- 
- Press [2] to review all aliases. While listening to each entry, press
    - [#] Skip to next alias.
    - [\*] [D] ([\*] [3]) Delete.
    - [2] [2] Return to the previous alias.
    - [#] Stop reviewing.
  - Press [3] to review specific aliases:
    - a. Enter alias to review and press [#].
    - b. Listen to corresponding address.
    - c. Repeat for more aliases.
    - d. Press [\*] [#] to stop reviewing.
3. Press [\*] [R] ([\*] [7]) to return to the Activity Menu.
- 

### **Tips**

Your personal directory activates automatically; the system refers to your personal directory anytime you enter a name address.

The system doesn't care what numbers or letters you use for each alias.

You should try to use 2- or 3-letter abbreviations that use people's initials. For example, for Mel F. Lewis, you might enter M F L instead of the longer name. You can also use an alias when transferring out of the system with [\*] T ([\*] [8]).

---

## **How to Use Directory Assistance**

---

If you know the name of a person, you can use the names directory to find that person's extension. If you know the extension, you can use the names directory to find the name of the person with that extension.



- 
1. Press **\* \* N (\* \* 6)** from anywhere in the system.
  2. Do one of the following:
    - To hear the extension number associated with a name, enter the name (last name first, with no spaces between the first and last name), then press **#**.
    - To hear the name associated with an address, press **\* A (\* 2)**, enter the address, then press **#**.

---

 **Tips**

The extension you hear associated with a name is not always the entire address.

You must add the appropriate prefix numbers for users on remote systems.

---

## **How to Leave a Call Answer Message**

---

When leaving a call answer message, you have several options for making full and efficient use of the system. When it answers the telephone, you can:

- Press **1** to dial through the greeting (if you won't be missing information in the greeting).
- Leave a detailed message (it's generally more efficient to convey information than just requesting a return call).
- Press **\* D (\* 3)** to delete and start over.
- Press **1 2 3** to stop recording and review your message.

Before or after leaving a message, you can:

- Transfer to another extension:
  - a. Press **\* T (\* 8)**.

---

b. Enter the extension.

c. Press .



**NOTE:**

If you record a message and either hang up or go to another option, the system automatically delivers your message to the person you are calling. To prevent delivery of your message, you must delete it with

( ) Command Summary

## BASIC COMMANDS













- \*H or \*4 Help
- \*R or \*7 Return to Activity Menu
- \*W or \*9 Wait
- \*\*N or \*\*6 Look up number/name
- \*\*X or \*\*9 Exit system
  - \*0 Transfer call to operator
- \*D or \*3 Delete
- \*\*U or \*\*8 Undelete  
*(not available on all systems)*
- \*\*H or \*\*4 Hold message in category
  - \*T or \*8 Transfer out
- \*\*R or \*\*7 Relogin

---













### Use while addressing:

- \*A or \*2 Alternate address (switch between name and number addressing)
- \*L or \*5 Use mailing list for addressing

## ACTIVITY MENU

Record & send 	Get & respond 	Create greetings 
Message file 	Mailbox options 	
Scan 		
Q = 7		Z = 9
		
		Skip

## PLAYBACK CONTROLS

	Rewind 	Pause/Play 	
Louder 	Back Up 	Advance 	
Softer 	Slower 	Faster 	
Q = 7		Z = 9	
			
	Listen/Replay	Skip	

---

## Tips and Highlights

---

### General Message Handling

Logging in quickly	From your telephone, dial the system extension, press # (you don't need to enter your extension), and enter your password.
Logging in from a system telephone	From any telephone connected to your company's system, dial the system extension, then enter your extension and password.
Logging in from a remote telephone	From any telephone not connected to your company's system, dial the complete system number, including local prefix and the area code if long distance, then enter your extension and password.
Dialing through	If you know which buttons to push, push them without waiting for the system to respond.



#### NOTE:

You can't bypass error beeps and important system messages.

For Help, press \* H (\* 4 ). The system states your current options or the next step.

---

## Getting Messages

Scan messages quickly	You can automatically play all your messages by pressing just two buttons, <b>7</b> plus either <b>1</b> to scan messages and headers, <b>2</b> to scan headers only, or <b>3</b> to scan messages only. Scanning is especially useful with a car telephone.
Use playback controls	When listening to messages, you have controls for loudness, speed, stepping back and forth, pausing, and repeating messages.
Record a personal greeting	Replace the automatic system greeting with your personal hello. Tell callers they can press <b>1</b> to skip your greeting and press <b>* H (* 4)</b> for Help. Change your greeting everyday to match your daily schedule.
Delete old messages	Your mailbox has limited space. When it's getting full, the system tells you. Delete messages or greetings you don't need.
Answer messages from your mailbox	Answer a message sent by another user immediately after listening to it, either by pressing <b>1 0</b> to call the person or by sending the caller a return voice mail message by pressing <b>1 7</b> .
Forward messages	You can forward a message to another user or a list of users immediately after listening to it. After you forward it, you return to the original place in your mailbox. To forward to a mailing list, press <b>* L (* 5)</b> to specify the list's address.

---

## Leaving Messages When No One Answers

Use playback and record controls	To listen to and edit the messages you leave when there's no answer, you have many controls.
Bypass greetings and record immediately	You don't have to listen to another user's call answer greeting. You can, instead, press <b>1</b> to bypass the greeting and begin recording immediately.
Use directory assistance	If you don't know the extension of another user, find it with your voice messaging system. Log in, press <b>* * N (* * 6)</b> and enter the person's name, last name first. The system tells you the extension.

## Sending Voice Mail

Make messages priority	When you want someone to listen to your message right away, send it as a priority message.
Make messages private	When you want to prevent another user from forwarding a message you send, make it private.
Save messages you send	Before sending a message, you can save it in the Outgoing Message file. Retrieve the message later to use again.
Check on receipt of messages you send	After you send a message, check your Outgoing Message file to see if the message was delivered and if the person listened to it.
Delete outgoing/ filed messages	Delete messages filed in the Outgoing Message file. Saved outgoing messages use system storage unnecessarily.

Schedule delivery	Schedule a message for delivery to others at a specified time and date. Use the system as a calendar/reminder by scheduling messages to yourself.
Use mailing lists	Create a mailing list of extensions. Then send your message to one destination—the mailing list. All extensions in the list receive the message. You can also forward messages to a mailing list.
Send messages to a name, not an extension	When you send a message and don't know the extension of the recipient, press <b>* A (*</b> <b>2]</b> ). Then enter the person's name, last name first. <b>* A (* 2]</b> switches you back and forth between extension and name.

To order additional copies of this document, call the AT&T GBCS Publications Fulfillment Center:

(800) 457-1235 (US telephone)

(800)457-1754 (FAX)

1 (317) 361-5353 (telephone outside US)

For more information about AT&T documents, see the AT&T Global Business Communications Systems Publications Catalog (555-000-010).

